

DVDO



DVDO-Fiber-1 18Gbps HDMI over Optical Fiber Extender with Audio Extraction

User Manual

Version 1.0.0

Thank you for purchasing this product

For optimum performance and safety, please read these instructions carefully before connecting, operating or adjusting this product. Please keep this manual for future reference.

Surge protection device recommended

This product contains sensitive electrical components that may be damaged by electrical spikes, surges, electric shock, lightning strikes, etc. Use of surge protection systems is highly recommended in order to protect and extend the life of your equipment.

Table of Contents

1. Introduction.....	1
2. Features.....	1
3. Package Contents.....	2
4. Specifications.....	2
5. Operation Controls and Functions.....	3
5.1 Transmitter Panel.....	3
5.2 Receiver Panel.....	5
5.3 IR Pin Definition.....	6
6. Application Example.....	7

1. Introduction

This HDMI Extender can extend HDMI signal up to 33000 feet/10 km (over single-mode fiber cable). It supports video resolutions up to 4K2K@60Hz 4:4:4. Transmitter supports loop output, audio embedding and EDID management function. Receiver supports audio extracting function. In addition, the extender supports bidirectional IR control and RS-232 signal pass-through. It can allow you to easily control the display device on the signal source side or control the signal source device on the display side when using this extender.

2. Features

- ☆ HDMI 2.0b, HDCP 2.2 and DVI 1.0 compliant
- ☆ Support 18Gbps video bandwidth
- ☆ Video resolution up to 4k2k@50/60Hz 4:4:4
- ☆ HDMI audio formats: LPCM2/5.1/7.1CH, Dolby Digital/Plus/EX, Dolby True HD, DTS, DTS-EX, DTS-96/24, DTS High Res, DTS-HD Master Audio, DSD
- ☆ Support 3D and HDR format video, does not support CEC control
- ☆ Transmission distance up to 33000 feet/10 km (over single-mode fiber cable)
- ☆ Support bidirectional IR control, RS-232 pass-through and EDID management for simple and convenient control
- ☆ Transmitter supports loop output (sharing local HD video and audio) and audio embedding function
- ☆ Receiver supports audio extracting output function
- ☆ Compact design for easy and flexible installation

3. Package Contents

- ① 1× 18Gbps HDMI over Optical Fiber Extender (Transmitter)
- ② 1× 18Gbps HDMI over Optical Fiber Extender (Receiver)
- ③ 1× IR Blaster cable (1.5 meters)
- ④ 1× IR Receiver cable (1.5 meters)
- ⑤ 2× 5V/1A Power adapter
- ⑥ 2× 3-pin 3.81mm Phoenix connector
- ⑦ 1× User Manual

4. Specifications

Technical	
HDMI Compliance	HDMI 2.0b
HDCP Compliance	HDCP 2.2
Video Bandwidth	18Gbps
Video Resolution	480i ~1080p50/60Hz, 4Kx2K@24/30Hz, 4k2k@60Hz
Color Space	RGB, YCbCr 4:4:4 / 4:2:2, YUV 4:2:0
Color Depth	8-bit, 10-bit, 12-bit
HDMI Audio Formats	LPCM2/5.1/7.1CH, Dolby Digital/Plus/EX, Dolby True HD, DTS, DTS-EX, DTS-96/24, DTS High Res, DTS-HD Master Audio, DSD
Transmission Distance	Up to 33000 feet/10 km over single-mode fiber cable
IR Frequency	20KHz-60KHz
RS-232 Baud Rate	4800-115200bps
ESD Protection	Human body model — ±8kV (Air-gap discharge) & ±4kV (Contact discharge)
Connection	
Transmitter	Input: 1 x HDMI IN [Type A 19-pin female] 1 x LINE IN [3.5mm Stereo Mini-jack] 1 x IR IN [3.5mm Stereo Mini-jack] 1 x RS-232 [3.81mm Phoenix connector] 1 x SERVICE [Micro USB, Update port] Output: 1 x HDMI OUT [Type A 19-pin female] 1 x Optical Fiber Out [LC female] 1 x IR OUT [3.5mm Stereo Mini-jack]

Receiver	Input: 1 x Optical Fiber In [LC female] 1 x IR IN [3.5mm Stereo Mini-jack] 1 x SERVICE [Micro USB, Update port] Output: 1 x HDMI OUT [Type A 19-pin female] 1 x RS-232 [3.81mm Phoenix connector] 1 x IR OUT [3.5mm Stereo Mini-jack] 1 x AUDIO OUT [3.5mm Stereo Mini-jack]
Mechanical	
Housing	Metal Enclosure
Color	Black
Dimensions	Transmitter / Receiver: 134mm [W] x 68mm [D] x 18mm [H]
Weight	Transmitter: 280g, Receiver: 278g
Power Supply	Input: AC 100 - 240V 50/60Hz Output: DC 5V/1A (US/EU standards, CE/FCC/UL certified)
Power Consumption	Transmitter: 3.85 W (Max), Receiver: 2.7 W (Max)
Operating Temperature	32 - 104°F / 0 - 40°C
Storage Temperature	-4 - 140°F / -20 - 60°C
Relative Humidity	20 - 90% RH (no condensation)

5. Operation Controls and Functions

5.1 Transmitter Panel

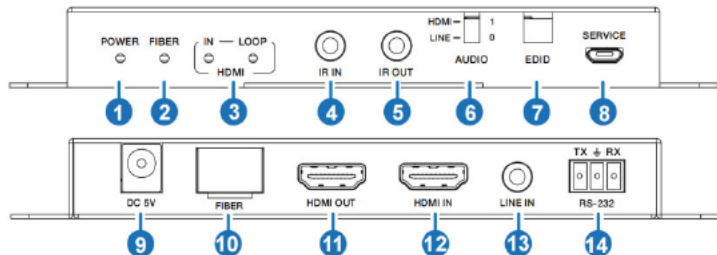

No.	Name	Function Description
1	Power LED	The power indicator is always on when the Transmitter is powered on.
2	FIBER LED	The optical fiber connection indicator is always on when the Transmitter and Receiver establish a normal optical fiber signal connection.
3	HDMI LED	IN: The HDMI signal input indicator is always on when there is signal input on the HDMI IN port.
		LOOP: The HDMI loop output indicator is always on when the HDMI OUT port of the Transmitter outputs signals to the HDMI display device.
4	IR IN	Connect to IR Receiver cable. The IR signal will send to the IR OUT port of the Receiver.
5	IR OUT	Connect to IR Blaster cable. The IR signal is from the IR IN port of the Receiver.
6	AUDIO switch	Switch to select audio signal source (HDMI IN or LINE IN). When there is no video signals input, audio signals can be transmitted separately.
7	EDID DIP switch	Dial the switch to set EDID. 11: Copy RX HDMI OUT 10: Copy TX HDMI LOOP OUT 01: 4K60_2CH 00: 1080P_2CH
8	SERVICE port	Firmware update port.
9	DC 5V	DC 5V/1A power supply port
10	FIBER	Connect the Transmitter optical fiber module, and transmit signals to the Receiver via an optical fiber cable
11	HDMI OUT	HDMI video loop output port, connect to HDMI display device such as TV or Projector with an HDMI cable.
12	HDMI IN	HDMI signal input port, connect to HDMI source device such as DVD or PC with an HDMI cable.
13	LINE IN	Audio signal input port, connect to audio source device such as MP3.
14	RS-232	RS-232 signal pass-through port for transmitting RS-232 command signals between the Transmitter and Receiver.

5.2 Receiver Panel

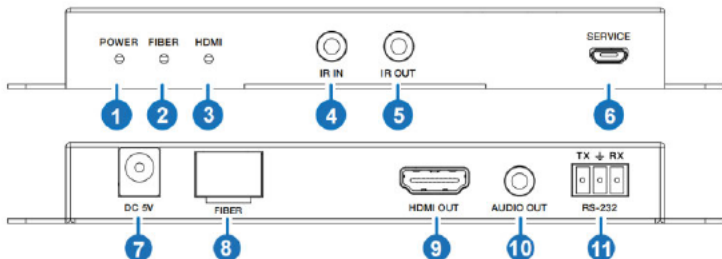

No.	Name	Function Description
1	Power LED	The power indicator is always on when the Receiver is powered on.
2	FIBER LED	The optical fiber connection indicator is always on when the Transmitter and Receiver establish a normal optical fiber signal connection.
3	HDMI LED	The HDMI signal output indicator is always on when the HDMI OUT port of the Receiver outputs signals to the HDMI display device.
4	IR IN	Connect to IR Receiver cable. The IR signal will send to the IR OUT port of the Transmitter.
5	IR OUT	Connect to IR Blaster cable. The IR signal is from the IR IN port of the Transmitter.
6	SERVICE port	Firmware update port.
7	DC 5V	DC 5V/1A power supply port
8	FIBER	Connect the Receiver optical fiber module, and receive signals from the Transmitter via an optical fiber cable.
9	HDMI OUT	HDMI signal output port, connect to HDMI display device such as HDTV or Projector with an HDMI cable.
10	AUDIO OUT	Audio signal extracting output port (extract the HDMI OUT audio signal), connect to audio output device such as amplifier or speaker.
11	RS-232	RS-232 signal pass-through port for transmitting RS-232 command signals between the Transmitter and Receiver.

5.3 IR Pin Definition

IR Receiver and Blaster pin's definition as below:

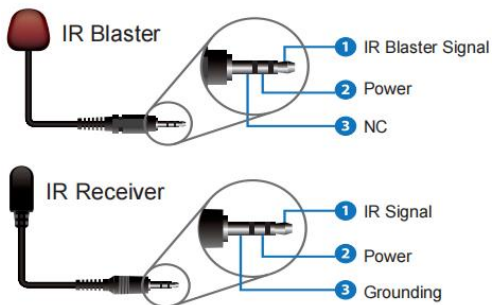

5.3 Optical Fiber Module



- ① SFP-BL32TG-10DC is the optical fiber module of the Transmitter.
- ② SFP-BL23TG-10DC is the optical fiber module of the Receiver.

6. Application Example

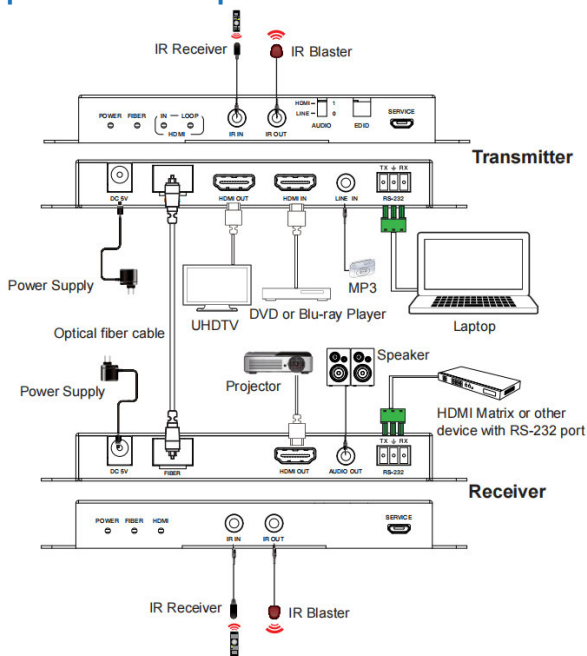

HDMI
HIGH-DEFINITION MULTIMEDIA INTERFACE

The terms HDMI and HDMI High-Definition Multimedia interface, and the HDMI Logo are trademarks or registered trademarks of HDMI Licensing LLC in the United States and other countries.